

--	--	--	--	--	--	--	--	--	--

B.Tech.
(SEM II) EVEN SEMESTER EXAMINATION, 2015-16
ENGINEERING MECHANICS

[Time: 3 Hours]

[Max. Marks: 100]

Note: (i). Attempt all questions. Marks are indicated against each question.
 (ii). Assume any missing data suitably.

1. Attempt any two parts of the following:-

[10x2=20]

(a) A sailor is being rescued using a boatswain's chair that is suspended from a pulley that can roll freely on the support cable ACB and is pulled at a constant speed by cable CD . Knowing that $\alpha = 30^\circ$ and $\beta = 10^\circ$ and that the combined weight of the boatswain's chair and the sailor is 900 N, determine the tension (a) in the support cable ACB , (b) in the traction cable CD .

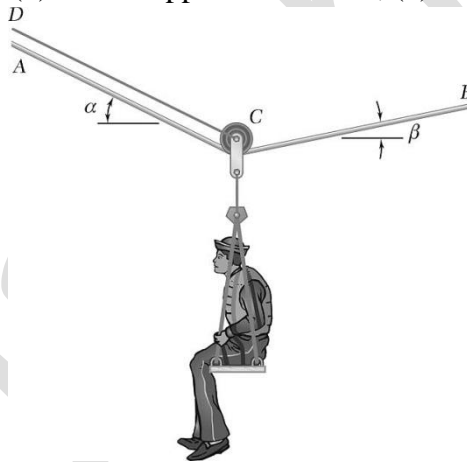

(b) A hand truck is used to move two kegs, each of weight 400 N. Neglecting the mass of the hand truck, determine (a) the vertical force P that should be applied to the handle to maintain equilibrium when $\alpha = 35^\circ$, (b) the corresponding reaction at each of the two wheels.

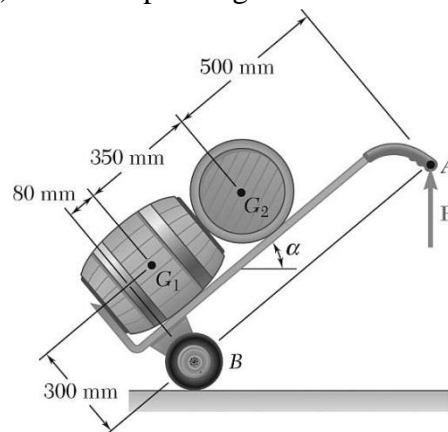

(c) The machine part ABC is supported by a frictionless hinge at B and a 10° wedge at C . Knowing that the coefficient of static friction at both surfaces of the wedge is 0.20, determine (a) the force P required to move the wedge, (b) the components of the corresponding reaction at B .

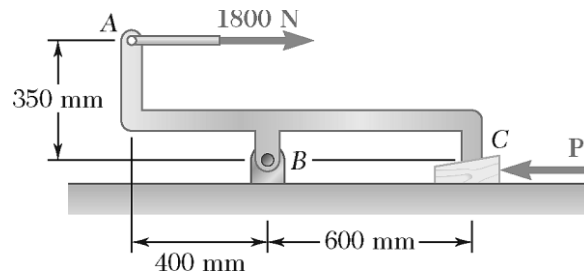

2. Attempt any two parts of the following:-

[10x2=20]

(a) For the truss shown in figure find forces in members AL, LK, KJ, CL, CJ and CK. Take dimensions as: AB=BC=CD=DE=EF=FG=BL=HF=2m, CK=EI=3m, and DJ=3.5m.

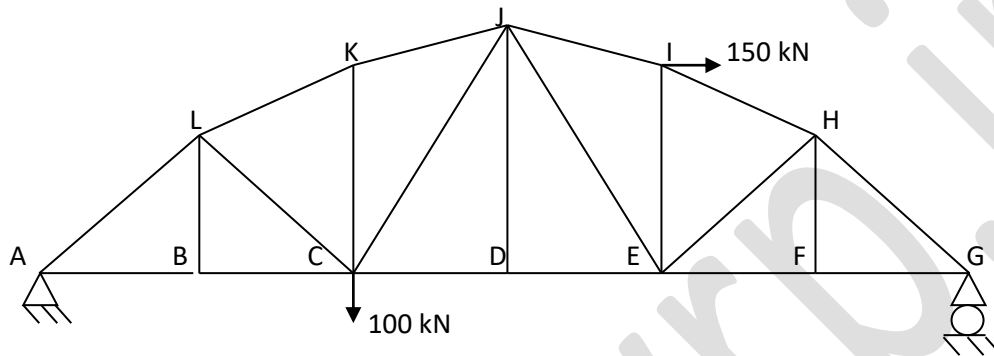

(b) For the Cantilever beam shown in figure find the equations for shear force and bending moment. Also draw the shear force and bending moment diagrams. Take $W_1 = 200$ kN/m and $W_2 = 100$ kN/m. [10]

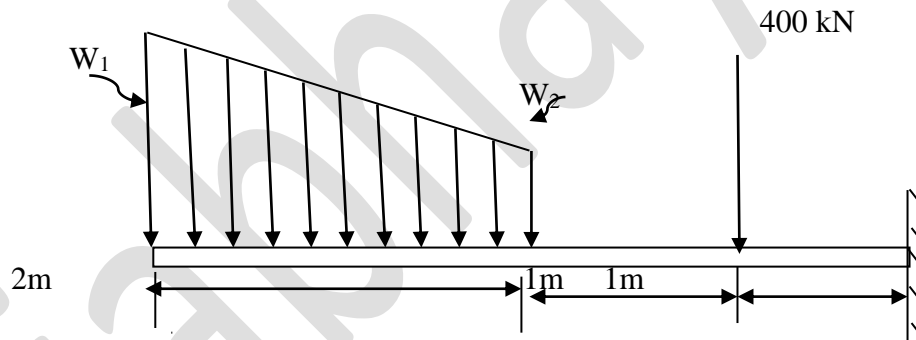

(c) For the beam shown in figure, taking the origin at A, find the equations for shear force and bending moment and draw SFD and BMD. The beam is subjected to a linearly varying load as shown in figure an A concentrated couple of 200kNm acts at 1m from end B.

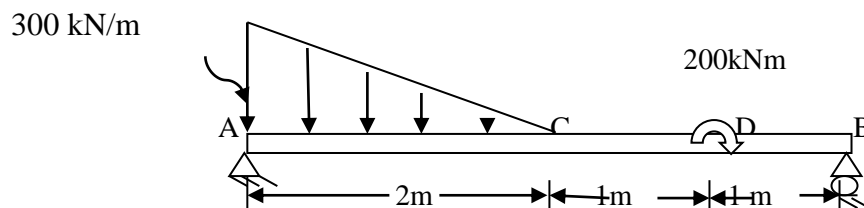

3. Attempt any two parts of the following:-

[10x2=20]

- (a) Determine the moments of inertia of the shaded area shown with respect to the x and y axes when $a = 20$ mm.

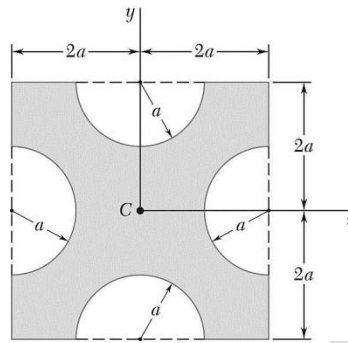

- (b) Locate the centroid of the plane area shown.

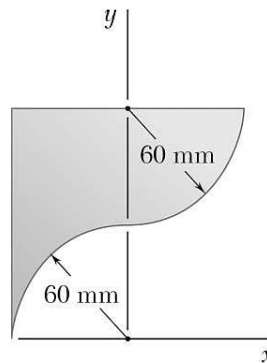

- (c) A thin plate of mass m is cut in the shape of an equilateral triangle of side a . Determine the mass moment of inertia of the plate with respect to (a) the centroidal axes AA' and BB' , (b) the centroidal axis CC' that is perpendicular to the plate.

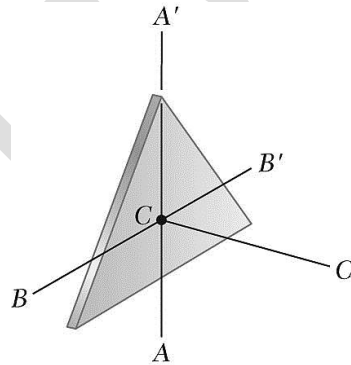

4. Attempt any two of the following:-

[10x2=20]

- (a) The motion of a particle is defined by the relation $x = t^3 - 6t^2 - 36t - 40$, where x and t are expressed in meter and seconds, respectively. Determine (a) when the velocity is zero, (b) the velocity, the acceleration, and the total distance traveled when $x = 0$.
- (b) A bullet enters a resisting medium at $x = 0$ with an initial velocity $v_0 = 900$ mm/s and travels 4 cm before coming to rest. Assuming that the velocity of the bullet is defined by the relation $v = v_0 - kx$, where v is expressed in mm/s and x is in mm, determine (a) the initial acceleration of the bullet, (b) the time required for the bullet to penetrate 3.9 cm into the resisting medium.

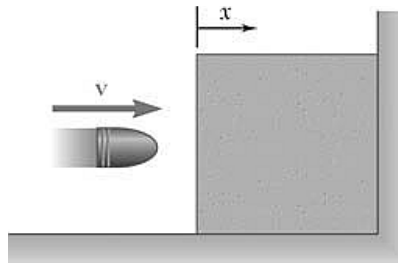

- (c) The coefficients of friction between blocks A and C and the horizontal surfaces are $\mu_s = 0.24$ and $\mu_k = 0.20$. Knowing that $m_a = 5$ kg, $m_b = 10$ kg, and $m_c = 10$ kg, determine (a) the tension in the cord, (b) the acceleration of each block.

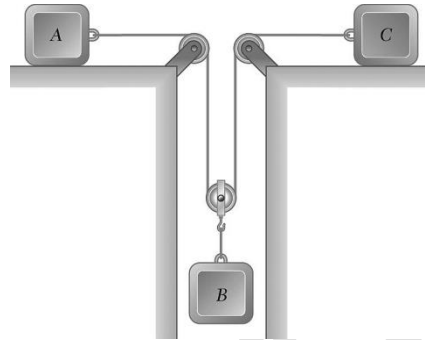

5. Attempt any two of the following:

[10x2=20]

- (a) Determine the suitable values for inside and outside diameters of hollow steel shaft whose internal diameter is 0.6 times its external diameter. The shaft transmits 220 kW at 200 rpm. The allowable shear stress is limited to 75 MPa, and angle of twist is limited to 1° per meter. The modulus of rigidity for shaft material is 80 kN/mm^2 . If the shaft is replaced by a solid shaft of same material with same weight (cross sectional area), determine the maximum power this solid shaft can transmit at 200 rpm with same conditions for strength and rigidity.
- (b) What is the difference between the neutral surface of the beam and neutral axis of the beam? Justify that the expression for flexural stresses derived for pure bending is applicable to the case when the bending moment varies with x .
A simply supported beam 10 cm wide by 80 cm high and 5 meter long, weighing 1000kN is subjected to a concentrated anticlockwise couple of 2000 kNm at a point 2 meter from the left support. Determine the maximum fiber stress and the stress in a fiber located 1 cm from the top of the beam at mid span.
- (c) (i) Define Poisson's ratio and deduce its minimum and maximum value
(ii) Prove that the shear stresses are maximum at 45° from cross sectional plane for a bar subjected to axial load.